

Installation Instructions & User Manual
for the super-efficient Mk2.

ECO Range T³

Log Wood burning
Thornhill Turbo Technology
5 Oven Cooker



Please retain these instructions for future reference.



WARNING

The ECO range cooker is wood burning only (this includes logs, sawdust briquettes and pellets); no attempt should be made to burn any other fuel, including all types of coal, smokeless fuels and petroleum coke. Under no circumstances should liquid fuels be added. It is not an incinerator and rubbish including painted or tanned wood and MDF should not be burnt in this appliance.

Any attempt is dangerous and will invalidate any guarantees immediately.

Technical data

<u>Built to</u> EN12815:2001 + A1:2004	<u>DEFRA approved</u>
Efficiency	90.1%
Emissions/CO concentration @13% Oxygen	0.1% Volume 1219 mg/m ³
Emissions Dust @ 13% Oxygen DEFRA UK Permitted 6.9g/h Max. Time above Ringelmann 2 - 10%	24 mg/ m ³ Actual 1.1g/h Actual 0.0 %
Fuel	Dry Logs < 25% H ₂ O 225 – 400mm long
Total Weight in kg	600 kg
kW output intermittent	5.9kW
Air vent requirement: Pre 2005 house Post 2005 houses Extractor fan	30mm diameter vent required. An air vent is required (60mm diameter) or direct to outside. Air vent required to match fan.
Minimum flue draught mm H ₂ O	0.8mm, 12PA
Mean Flue Gas Temperature	122 °C
Flue size Min. chimney diameter Max. chimney diameter	150mm (6") 150mm (6") 200mm (8")
Minimum distance to combustible materials	50mm behind (2"). 100mm at Fire box side (4"). 80mm (3") fire box side if 40mm insulation 40mm (1 3/4" oven side)
Max. Hearth temp. Min. Hearth thickness	<100 °C 12mm

Appliance Details

Overall Size: Height (to hob)	910mm
Width	1490mm
Depth (to towel rail)	720mm

Flue 6" (150mm), centre line 500mm from the fire box side, plus centre line 125 mm from the rear surface

Hotplates: 340mm diameter x 2 with center

3 Ovens: Height	280mm
Depth	525mm
Width	355mm

Installation Instructions

When installing these appliances, all local regulations, including those referring to national & European Standards need to be complied with.

This manual covers the ECO Range cooker appliance.

The nominal space heating output is: 5.9 kW

The above appliances must be installed by the manufacturer or by a HETAS registered installer and the installation registered with the local council.

Failure to comply with the above renders all guarantees and liabilities of the manufacturer null and void.

The manufacturer will not guarantee or accept liability for any problem that arises unless, a HETAS installation commissioning certificate has been completed and a valid receipt or proof of purchase is presented from the approved supplier.

The appliances should not be fitted closer than shown in the chart, from combustible materials, e.g. a wooden fire surround or stud wall.

When fitted against a wall made of combustible material e.g. a wooden stud wall with plasterboard, if the distance is less than the safe distance specified, extra non-combustible material of 75mm (min.) should be fitted behind the stove. When fitted inside a masonry or similar non-flammable material recess, e.g., fireplace opening, there is no minimum distance; the gaps are only an aesthetic consideration.

Hearth

The cooker should stand on a non-combustible hearth of minimum thickness 12mm (1/2"). This should extend a minimum 225mm (9") in front of the cooker. When the cooker is free-standing, the hearth should extend a minimum of 150mm (6") on either side of the cooker. The hearth must be capable of taking the load of the appliance. Suitable measures, (e.g. a load distribution plate) should be taken if not, to ensure stability.

Air supply

All hydrocarbon burning appliances require an oxygen/air supply.

Under Reg J in the UK, an air vent is required for older properties built before about 2005 of a minimum of 30mm diameter. Properties that have been 'improved' with extra insulation and draught proofing of windows and doors do require a vent of 60mm diameter minimum.

If the chimney/cooker is to be fitted on an external wall the air supply can be taken straight from the outside. A 3" (80mm) diameter hole needs to be drilled in the correct place, 138mm above the hearth and the cooker 'manifold/extension air pipe' kit purchased and fitted. A proprietary grille is supplied with the kit, if not used an air brick or non-closing vent should be fitted to ensure the air supply is not blocked in any way.

The manifold method of supplying air is always to be preferred as there will be no draught in the room, especially when the cooker is not in use.

If the cooker is not on an outside wall or the direct air supply method cannot be used, an air vent must be supplied in the room in which the cooker is fitted.

Only permanently open vents can be used and consideration should be given to draught when the cooker is not in use. Site these vents carefully. The vent covers should comply with Building Regulations Part J and should be sited where they cannot be blocked.

Extractor Fans: These suck air out of the room and cause negative pressure in the room so they must have their own air vent to counter this. Even when the air is taken directly from the outside using the manifold system, a vent will be required for any extractor fan fitted in the same room or adjacent rooms. Great care must be taken with restaurant/café kitchens which have professional levels of extraction.

Chimneys

A chimney of minimum 6" diameter (150mm) and a minimum length of 4 meters and it must comply with Building Regulations J. Never share the flue with another appliance.

Without a chimney to Building Regulations specifications there could be insufficient draw on the chimney to pull enough oxygen through the appliance to make it burn properly.

If you live in a valley or are surrounded by tall trees or buildings, you might experience downdraught problems where the wind tries to stop the fumes rising up the chimney. An anti-downdraught cowl might help, but anti-downdraught cowls reduce draw, so will not work on single storey chimneys and those with insufficient draw.

We recommend you seek the advice of the manufacturer or a HETAS or NACE registered supplier and installer before purchasing any cooker or heating appliance.

We recommend any chimney larger than 200mm is lined using a Class I liner, and backfilled with insulation to Building Standard requirements. We recommend using the ECO Range register plate adaptor and adjustable vitreous enamel flue pipe which is designed for easy fitting.

Chimney design/specification for Thornhill Range Cookers wood and pellet fired cookers.

The chimney is an integral part of a wood burning appliance and, as such, the design and function of the chimney greatly affects the working of the appliance.

The job of the chimney is to cause a partial vacuum and draw air/oxygen through the combustion chamber to allow combustion.

Too strong a draw and the appliance becomes inefficient as heat is drawn up the chimney and thrown away.

A weak draw, no draw or a back draught will stop the fire burning properly, go out or push smoke back into the room.

Equally, if the room is gas tight, air cannot enter to pass through the appliance and up the chimney, so a very sealed room needs an air supply for the appliance, and if an extraction fan is fitted a larger vent is required or it can draw the smoke back down the chimney and out of the appliance into the room. (a problem in restaurants/professional kitchens which have massive extraction fans)

If the house is newly built and relatively gas tight, an air vent of at least 60mm diameter must be fitted at least 100mm if an extractor fan is fitted.

Flue pipe, single skin pipe of stainless steel or Vitreous enamelled steel is used to connect the appliance to the chimney.

Class I Twin wall insulated flue is a chimney and is equal to a brick built/lined chimney.

Golden Design Rules:

- a) No more than 2 metres of single skin flue pipe should be used. (it causes the flue gases to over-cool and lose their lift)
- b) No more 4 x 45-degree elbows should be used, in the flue and the chimney.
- c) Distance to flammable materials (plasterboard is cardboard backed and flammable), Chimney 60mm, flue pipe 3 X diameter so 450mm on the wood cooker.
- d) A soot door/sweeping door must be provided, in the first section of flue pipe or at the first bend.
- e) An adjustable section must be used to be able to remove the flue pipe for maintenance. Twin wall must **NOT** be built up from the appliance, using the appliance as support.
- f) The chimney should terminate 2.4metres horizontally from a tiled surface, as per the diagrams below.
- g) A terminal must be used with a bird mesh between 12mm and 25mm. A storm type is preferable. See diagram.
- h) Brick build chimneys must be lined down to the correct diameter for the appliance.
- i) The diameter of the lining must not be smaller and not be excessively larger than the flue diameter of the appliance. i.e. an appliance with a 150mm flue can be used on a 150 to 170mm diameter chimney, but not on a 125mm or 200mm chimney.
- j) If it is a very tall chimney or larger than standard, the draw should be measured with a manometer. The draw should be between 10-15PA. Above that and the efficiency will start to drop. Over 20PA and you can start to affect the appliance and a flue or barometric stabilizer will have to be fitted and set to 12-15 PA.

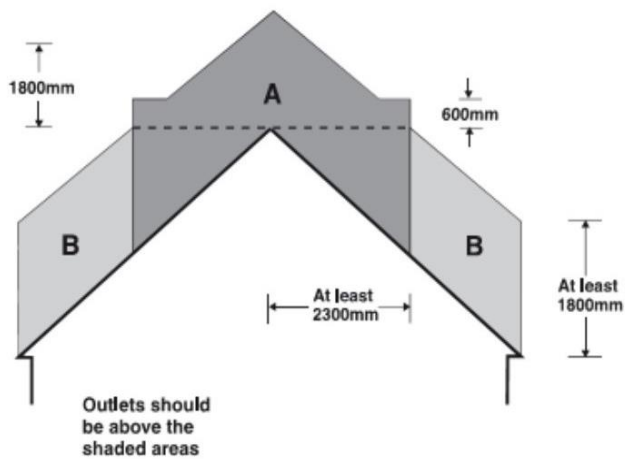

Area	Location of flue outlet
A	At least 1800mm vertically above the weather surface and at least 600mm above the ridge.
B	At least 1800mm vertically above the weather surface and at least 2300mm horizontally from the weather surface.

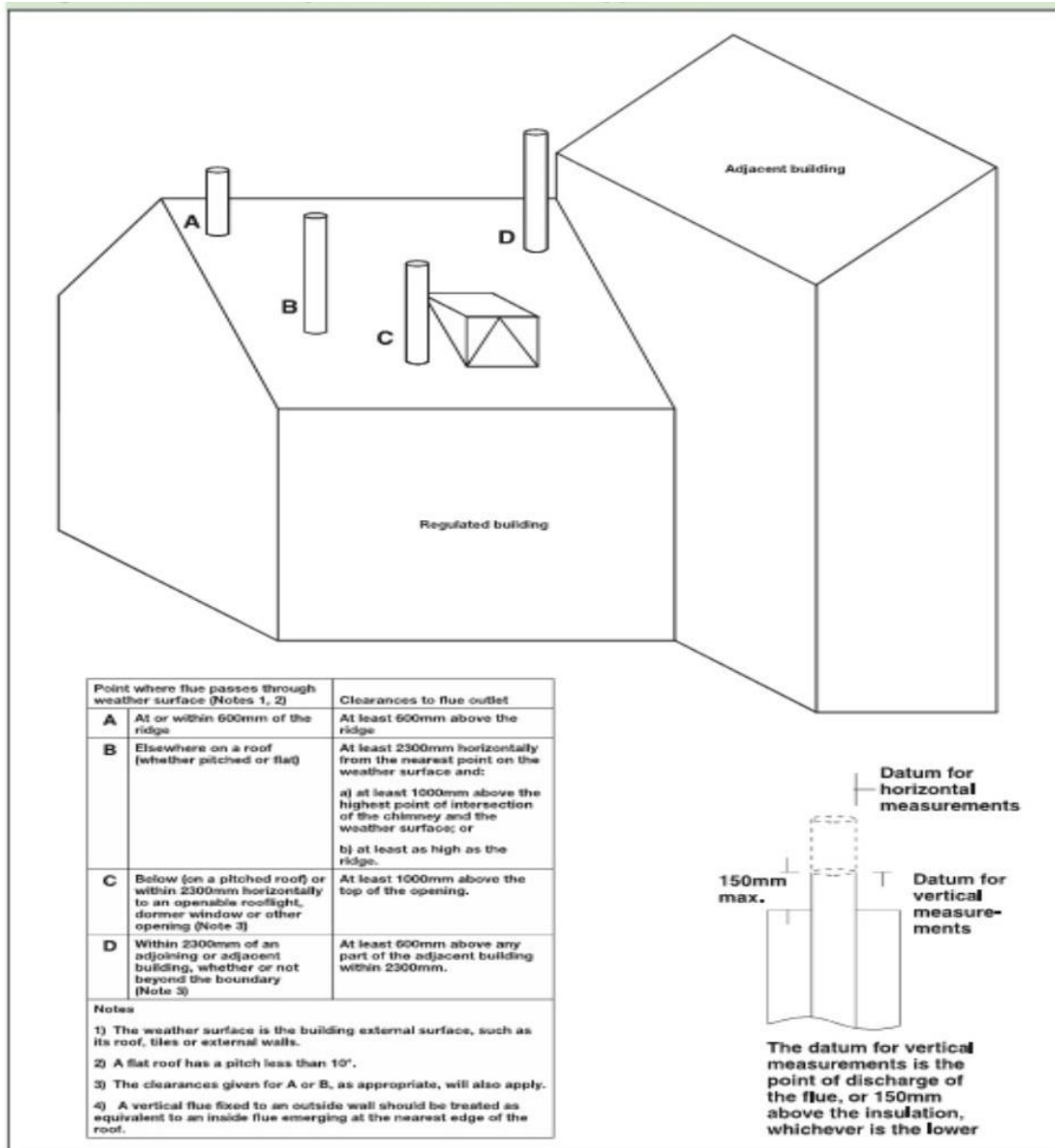

Barometric draft Stabilizer



Storm Cowl

Commissioning of the ECO Range wood fired cooker appliance

On completion of the installation, when any fire cement or paint used has dried, the stove can be lit, a smoke 'pellet' should be burnt and all joints checked for smoke leakage and the chimney draw checked with all doors and windows closed.

Please leave the instructions with the customer and inform them;-

- 1/ When they light the fire for the first time, 'smoke' will appear around the cooker and flue pipe with a strong acrid smell. This is normal and is the paint curing. If the stove is fired properly for at least 2 hours this should not happen again.
- 2/ That they should fire it quite hard for at least half an hour every time the stove is lit, to warm the cooker, flue pipe & chimney. It can then be turned down, but if kept running at a low temperature it will tar up and become less efficient.
- 3/ You cannot have wood fuel too dry, wood should be at about 20% maximum moisture content. Mixing wood that is 25% with manufactured logs @ 2-10% helps to keep the average moisture down and the stove working efficiently.
- 4/ Never empty all the ash; it is required to help keep the combustion chamber temperature up for an efficient clean burn.

USER INSTRUCTIONS

General operation

The knob on the left is the air slide control, out increases air to the cooker and in will slow the burn rate down.

Above the combustion chamber is a second knob - the top hotplate lever - which controls a baffle above the fire.

This is used for 2 purposes:

- 1/ Out: Allows a simpler route for the flames to the flue to give them a chance to heat up quickly when lighting the cooker and to increase the heat to the hot plate and reduce the heat going to the ovens. So a fresh log and the knob pulled out will help you fry on the firebox side of the hot plate.
- 2/ In: increases the flow of hot gases around the top oven, and the cooker runs at its most efficient. This is the normal running position once the appliance is hot. In summary, the knob is out only for lighting and quick bursts to the hot plate.

Using your hotplates

Your appliance has two hotplates, with a joint plate in the middle, protected with two insulated lids which should remain in a closed position when not using the hotplate. The lids can be raised independently if only using one hot plate. The hot plate temperature can be increased by pulling out the top baffle (as above). This allows the flame straight up to the hot plate and can heat it up faster. The higher the temperature in the ovens, the hotter the hotplate will become.

The design of the hot plates is such that the side above the firebox will become the hottest, making this suitable for deep fat frying, shallow frying and boiling. The other side plate is best for simmering and slow boiling. The surfaces of the hotplates are ground smooth and it is therefore recommended that all utensils used have a solid, flat base to come in complete contact with the hot plate for efficient results. Aga or Le Creuset type saucepans are good.

Using your Ovens

Your appliance has 3 wood-fired ovens. The thermometer dial in the top oven door provides an indication to the top oven temperatures. This thermometer reading will reduce quite dramatically when the door is opened and only recover slowly when the door is closed. This occurrence does not mean that the oven temperature further in has reduced, just that the door liner and temperature probe has cooled. The bottom ovens are warmed by the underside of the oven or firebox above. Depending on the control device setting and operational time, these ovens will generally operate some 85 – 90°C below the top oven. They may be used for small food cooking, biscuits, cakes etc but are best used as a warming compartment.

To light the cooker

It is important to keep an approximate minimum depth of $\frac{3}{4}$ " (20mm) of wood ash in the fire box at all times. You will achieve this after the first few firings.

Place 1 or 2 firelighters in the bottom, then some kindling wood or briquettes crisscrossed diagonally, and finally 2 larger logs on top. Light the firelighters, open the air vent to maximum (to the right) and close the door to the first latch so there is an air gap around it.

Pull the top hot plate lever out to maximum, to increase the draw.

Pull the air vent slider out to maximum to increase the draw.

Leave it like this for at least five minutes and then add a further 2 logs. After about a further 5 minutes or so, the fire should be well alight, and the door can now be closed to become air tight. Leave the air control lever near the maximum (to the right) for a further 10 to 20 minutes to get the cooker completely up to running temperature.

If you want to get the oven to temperature in the fastest time, use small split logs and leave the door on the first latch, the air slide at maximum and the top hot plate lever in.

The best running position to achieve maximum efficiency will depend on the chimney draw, but will be normally be near the centre. Every chimney is different, and you will find your cooker's optimum position. This is when the flames are swirling in a lazy manner around the cooker, not roaring. If the lever is pushed too far in, you starve the fire of oxygen, causing the glass to darken. Move the lever a small amount out until the glass just stays clean. Once your cooker is up to temperature, and you have found your optimum running position, it is best not to move it.

The best way to run any wood cooker is 'little and often', if you are around it is best to keep adding a small log (approximately 1kg) every 45 minutes rather than adding 4 large ones every 2 hours.

THE COOKER IS NOT DESIGNED TO BE USED WITH THE COMBUSTION CHAMBER DOOR OPEN

To reload, pull open the air vent on the left hand side and the top hot plate lever out as well, and then open the door slowly. Push some of the burning charcoal to the back of the combustion chamber and, using gloves/gauntlets (welding ones are very good) ; place the fresh log towards the front of the appliance.

Close the door and after 1 minute return the air slide to the central or desired position.

After being used 10 -20 times some ash might need to be removed. Never empty all the ash, leave at least $\frac{3}{4}$ " (20mm) in the bottom. Ensure the fire is out before trying to remove any ash.

Using a small metal shovel, scrape back the top layer to one side and scoop out some of the lower ash. You can place cold ashes on your compost heap or directly round fruit trees or rose bushes.

Never put hot ashes in a plastic dustbin.

Spread the remaining ash back evenly over the base of the fire box and you are ready to relight the cooker.

Smokeless Zones

The ECO Range T3 is almost certainly the cleanest wood burning cooker in the world and so is DEFRA approved for burning wood in 'smokeless' zone in cities.

Smoke and pollution is generated at 2 main critical times:

- 1/ When lighting.
- 2/ When adding fresh fuel.

To reduce nuisance at these times:

- a) Ensure you light quickly with plenty of tinder wood (soft wood, old pallets are excellent source) or manufactured fuel from compressed sawdust, in the form of briquettes. Open the air vents and keep open till the stove/cooker is very hot, about 10-15 minutes.
- b) Use dry fuel, load small amounts frequently where possible, about 1.5kg is ideal, don't let the embers get to cool, and don't exceed the maximum load which is about 2kg.
- c) If the fire bed has gone low and there is insufficient burning material in the fire bed to light a new fuel charge, excessive smoke emission can occur. Refuelling must be carried out onto a sufficient quantity of glowing embers and ash to ensure that the new fuel charge will ignite. If the fuel bed is too low or cool, suitable kindling must be used to re-light the flames.

Remember smoke is un-burnt fuel being wasted up the chimney and costing you money as well as polluting the atmosphere.

Glass

Simple glass cleaner will keep the cooker glass fresh most of the time, with a proprietary cooker / stove glass cleaner being needed once a month or so to deep clean any stains.

The glass is double glazed; check the rope seals and screws regularly to ensure a long life.

In the event of a glass breakage, lift the door off and place on a flat surface. Undo the 4 screws holding the glass fixing brackets and place to one side. Remove the sheet of glass and clean the un-broken one. Check the door seal and replace if required. The seal/rope is ready glued, peel back the cover strip and push into place, cut to length using a sharp craft knife.

Glue the second seal on the first pane of glass and place the second sheet over this.

Replace and tighten the screws and brackets. Take care not to over-tighten the screws. The glass has to expand and contract with each lighting, and the rope seal lets this movement happen.

Chimney sweeping & maintenance

Your chimney should be swept at least once a year by a registered sweep, twice a year with heavy use. The sweep should also replace the fire cement at the base of the flue if necessary.

The chimney sweep must also remove the hot plate using the handle provided and vacuum inside very gently, inspecting the condition of the baffles.

Also the inspection cleaning plate in the middle of the bottom, of the top oven, must be removed and the chamber vacuumed clear of ash.

All rope and glass seals should be checked annually and replaced as necessary.

If the cooker has not been used for a prolonged period, in excess of 6 months, the chimney should be swept prior to use to check for blockages and rubble and debris blocking the flue ways.

NOTE; All solid fuel appliances produce considerably more Carbon Monoxide in normal use than oil or gas appliances. But the general 'smell' of the smoke or exhaust is much stronger (with perhaps the exception of smokeless fuel) and more easily detected by a healthy person. Always use your appliance with the doors shut and look for telltale signs of excessive leakage. Smoke stains above the firebox door, smoke emitting around the door when running, smoke stains where the vitreous enamel flue meets the chimney or register plate, a strong smell of soot upstairs etc. There is no such thing as a gas tight chimney, but there has to be a negative pressure inside a chimney for it to draw oxygen through the fire box. Check the seals at the joints annually and re-fire cement as required, check especially the joint of the flue pipe to the chimney register plate. Hairline cracks are OK, but lumps of cement missing are a bad joint. A proper proprietary joint should be used here, as they are far superior to cement and rope seals.

Never block air vents internally and externally

The surface of the appliance is hot in normal use; guards should be used when young children or infirm people are around. Avoid all flammable materials within 300mm of the appliance.

In the event of a chimney fire, shut the air vent right down. If possible, throw table or dishwasher salt onto the fire.

Never modify or fit parts not recommended by the manufacturer to the appliance.

Never use this appliance in the same flue as another appliance.

Trouble shooting:

In essence a wood stove or cooker is a fairly simple, robust appliance, and although modern ones are more sophisticated than 10 years ago, they are not full of parts that fail easily & it is nearly always obvious if one of these parts has been broken or has failed. The glass is double glazed so if the inner or outer glass cracks the appliance is still safe to use for a few days till the broken glass can be replaced. It is a simple screwdriver job and does not require professional attention.

Baffles are made of stainless steel or 'vermiculite': compressed, expanded volcanic rock, a bit like chip board. If these crack, again it is not a major problem and no harm will occur as long as they haven't fallen out, exposing the walls behind them. Of course they should be replaced if excessively cracked or broken, as soon as possible, and these parts all slot into place. Spares can be ordered from the manufacturer, or cut from a sheet of Skamolox board using a wood saw, and the old broken baffle as a template.

If installed correctly, running problems can only be caused by:

- a) Poor and/or wet fuel
- b) Poor chimney.

Fuel should be cut and split and then stored for a minimum 2 years to bring the water content down below 20%. That's still a lot of water 200ml/1kg log! You cannot burn water and it reduces the efficiency of the appliance dramatically. If you can purchase a small moisture meter (about £15.00), then take a sample log and split it, press the meter into the newly exposed wood. That is the only way to check your wood.

The word 'seasoned' is meaningless, and usually a con trick.

Chimneys: If you definitely have dry wood but are still having difficulty with your wood burning appliance, it is almost certain that it is the chimney.

Chimney problems divide into 2 clearly different sections: Down Draught & Lack of Draught.

Lack of draught: A chimney is like a hot air balloon: the air inside wants to rise up as it is hotter than the air outside. The 2 things that determine the performance of a hot air balloon are the size of the balloon, which equates to the height and diameter of your flue, and the temperature of the air inside, which equates to the quality of the chimney. If the pilot wants to go up he turns the burner on and heats the air so it has more lift. If you have a large 'cold' chimney, as the smoke goes up it will cool and lose its buoyancy. This stops the rise and it is this rise, or draw, that draws the oxygen through the fire to make it burn. Without the lift or draw there is insufficient oxygen, and the fire just smoulders on.

Signs of lack of draw: When, at all times, burning good dry fuel the cooker struggles to get to temperature and when the door is opened to re-fuel, large quantities of smoke come out.

Solutions: Check that the flue is not blocked in the first place. Line the chimney, insulate the chimney/liner. No cowls will increase draw, they all reduce it.

Down Draught: A roof is like the wing of an aircraft or the sail on a boat and causes pressure changes as the wind flows over and around it. To make matters worse, the surroundings also affect the flow and pressures. So if a chimney is not 'tall' enough it can end up in a high pressure zone, the air will then want to come down the chimney and out the back or front door, which can be at a lower pressure.

Signs of a down draft: When burning good dry fuel the cooker struggles to get to temperature and when the door is opened to re-fuel, large quantities of smoke come out, only on certain days only when the wind is blowing from a particular direction. (Usually from the opposite side of the roof that the chimney is

Solutions: Raise the chimney, add more twin wall or fit a taller pot. Cut down surrounding trees. Fit a 'Verdette' or spinning type of cowl.

Flue spigot 150mm diameter to fit 6" Vitreous enamel flue pipe

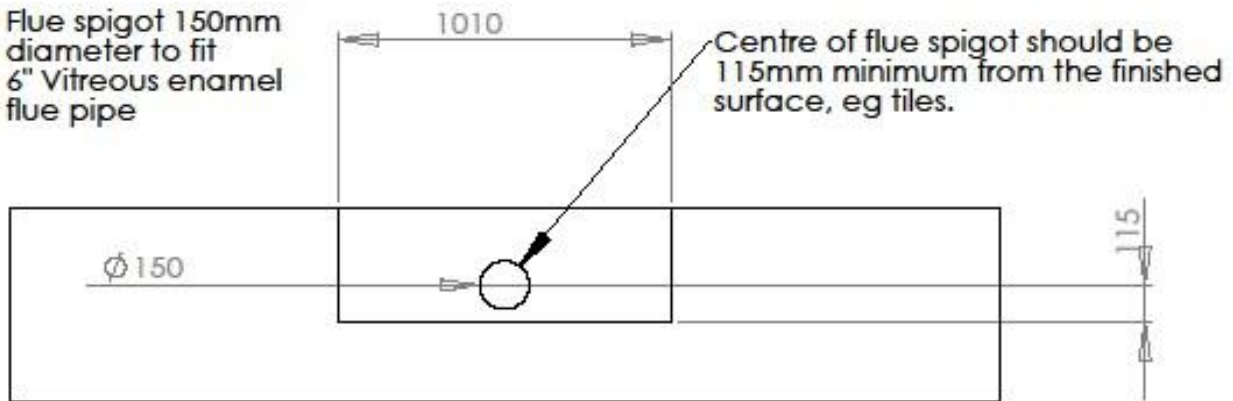

Minimum width of opening to non flammable surfaces 1010mm
 Minimum height to clear lid handle when opening 1,400mm

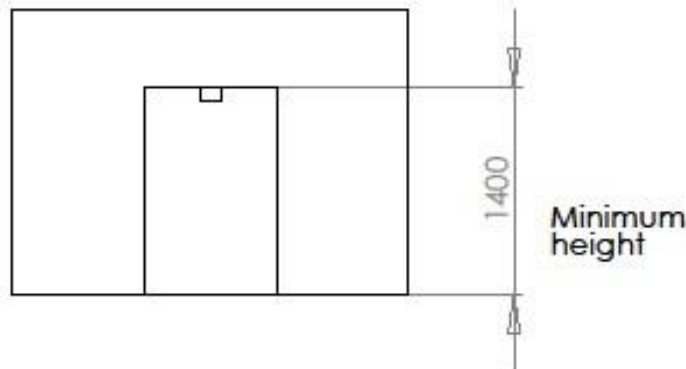
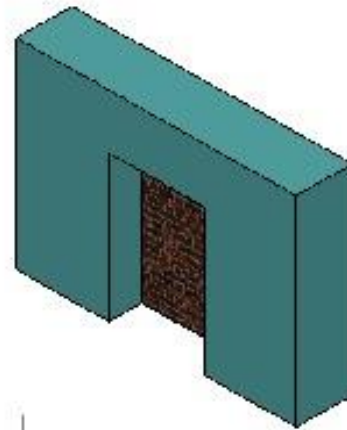



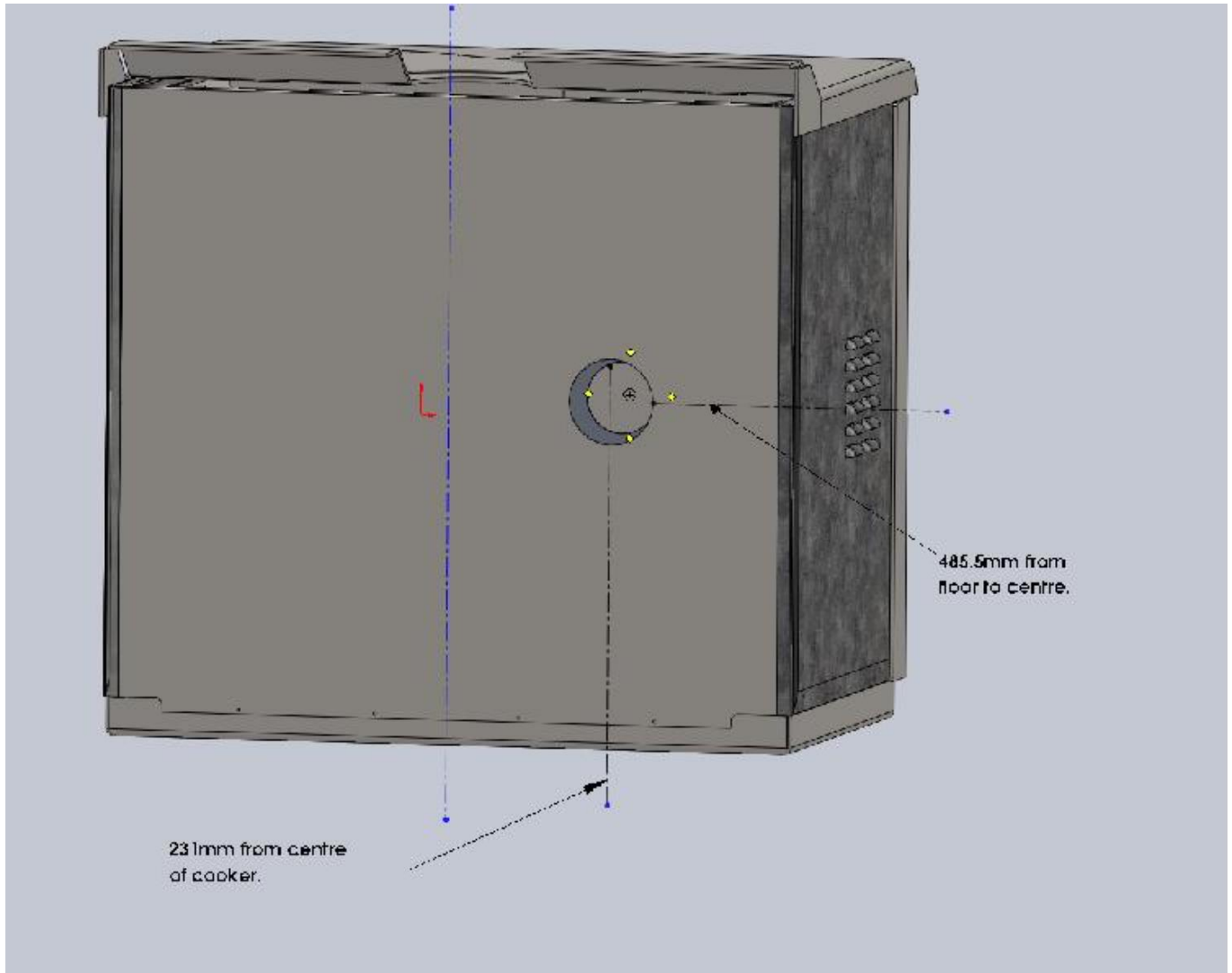

UNLESS OTHERWISE SPECIFIED: DIMENSIONS ARE IN MILLIMETERS SURFACE FINISH: TOLERANCES: LINEAR: ANGULAR:			FINISH:		DEBUR AND BREAK SHARP EDGES		DO NOT SCALE DRAWING		REVISION	
NAME			SIGNATURE		DATE		TITLE:			
DRAWN										
CHK'D										
APP'VD										
MFG										
Q.A.					MATERIAL:		DWG NO.		6inch flue diagram A4	
					WEIGHT:		SCALE:1:50		SHEET 1 OF 1	

Position of direct air manifold. Pipe is 120mm diameter.



Spare Parts- Prices as Jan 2023 – Mark 2 Wood Cookers (Jan 23-)

Item (excluding postage and packing)	Cost Excl. VAT	Cost Inc. UK VAT
	£	£
Glass per piece (Inc. rope) (Usually only change the inner)	25.80	30.96
 Lower Stainless baffle (must specify L or R firebox)	79.20	95.04
Mesh and stainless pop rivets	18.00	21.20
Vermicuboard per sheet 600mm X 500mm	72.00	86.40

	Liner set lower 4 pieces, these are the one at the base with the holes in.	90.00	108.00
Liner set higher 4 pieces, These are either side and back		90.00	108.00
	Top baffle and slider.	108.00	129.60
Door rope each		15.00	18.00
Glue for door rope & lid seals		12.60	15.12
Lid seals (AGA) (each)		19.00	22.80
Lid liners (AGA) (each)		19.00	22.80
Kit: 2 liners, 2 seals, tube glue		82.00	98.40
Touch up paint (please specify colour)		20.83	25.00
Spare oven racks (AGA)		27.00	32.40
	2 ring ceramic hob	85.00	102.00



'Thornhill Turbo Technology' is the patented clean burning 'engine', used under license in these cookers.

Thornhill Range Cookers

Unit 1, Sunrise Complex

Canterbury

Kent CT1 3RA